

ASP[®] SELF PRIMING PUMP EM SERIES



Applications

- EM Series Self-Priming Pumps are suitable for pumping clean water, lube oil or diesel oil of domestic or industry.
- * Deep well water supply
 - * Diesel station
 - * Oil circulating system
 - * Pressure boosting of water/oil

Material

- * Bronze / Stainless Steel Casing
- * Bronze Impeller
- * Stainless Steel Shaft

Working Conditions

- * Max. Pressure: 10 bar
- * Max. Medium Temperature: up to +50°C
- * Max. Ambient Temperature: 0°C to +40°C
- * Insulation Class B, Protection IP44, Thermal protector

Pump Key

EM - 20 B T

- T: 3 Phase None: 1 Phase
- B: Bronze S: Stainless Steel
- Inlet & Outlet Diameter (mm)
- EM Series Self-Priming Pump

Model	Input Power		Max. Head (m)	Max. Capacity (L/min)	Suction Head (m)	Current (A)	Capacitor (UF)	Inlet & Outlet (mm)	Flow Rate	Capacity (L/min)							
	(KW)	(HP)								10	20	30	40	50	60	70	
EM-20	0.37	0.5	10	47	9	1.6	12	20	Head (m)	8	6	4	2				
EM-25	0.45	0.6	12	55	9	2	12	25		9.5	7.5	5	3	1			
EM-30	0.75	1	14	65	9	3	20	30		12	9.5	7.5	5	3	1		
EM-35	0.9	1.2	16	75	9	3.4	20	35		14	12	9.5	7.5	5	3	1	

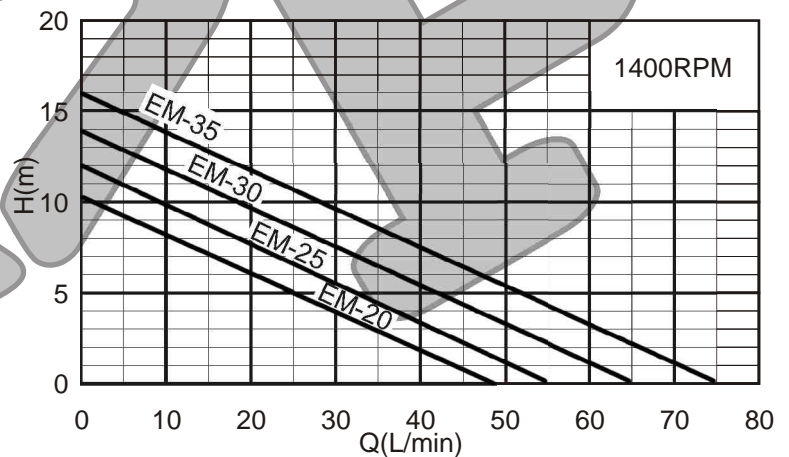
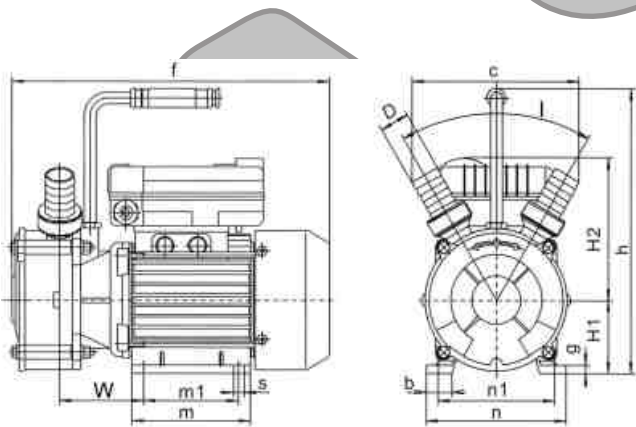

Model	Installation Dimension (mm)														Weight (kg)		Overall Dia. (LXWXH)mm
	f	c	h	H1	H2	l	m	m1	n	n1	w	b	g	s	NW	GW	
EM-20	270	140	242	63	121	60°	100	80	120	100	72	23	8	9	5.2	6	300x155x195
EM-25	270	145	242	63	121	60°	100	80	120	100	72	23	8	9	5.5	6.3	300x155x195
EM-30	300	170	262	71	135	60°	110	90	134	112	83	23	9	9	7.5	8.5	320x185x215
EM-35	300	175	262	71	135	60°	110	90	134	112	83	23	9	9	8	9	320x185x215



THONG FATT JAYA MACHINERY HARDWARE SDN. BHD.

同發機械五金有限公司 (176024-V)

707-709, Jalan Kuala Kangsar, Taman Tasek Jaya, 31400 Ipoh, Perak, Malaysia.
Tel: 00-605-5468 659, 5455 751, 5479 196, 5454 107
Fax: 00-605-5482 282, 5474 753
Email: tfjaya@streamyx.com / tfjaya@tm.net.my
Website: http://www.thongfattjaya.com.my