

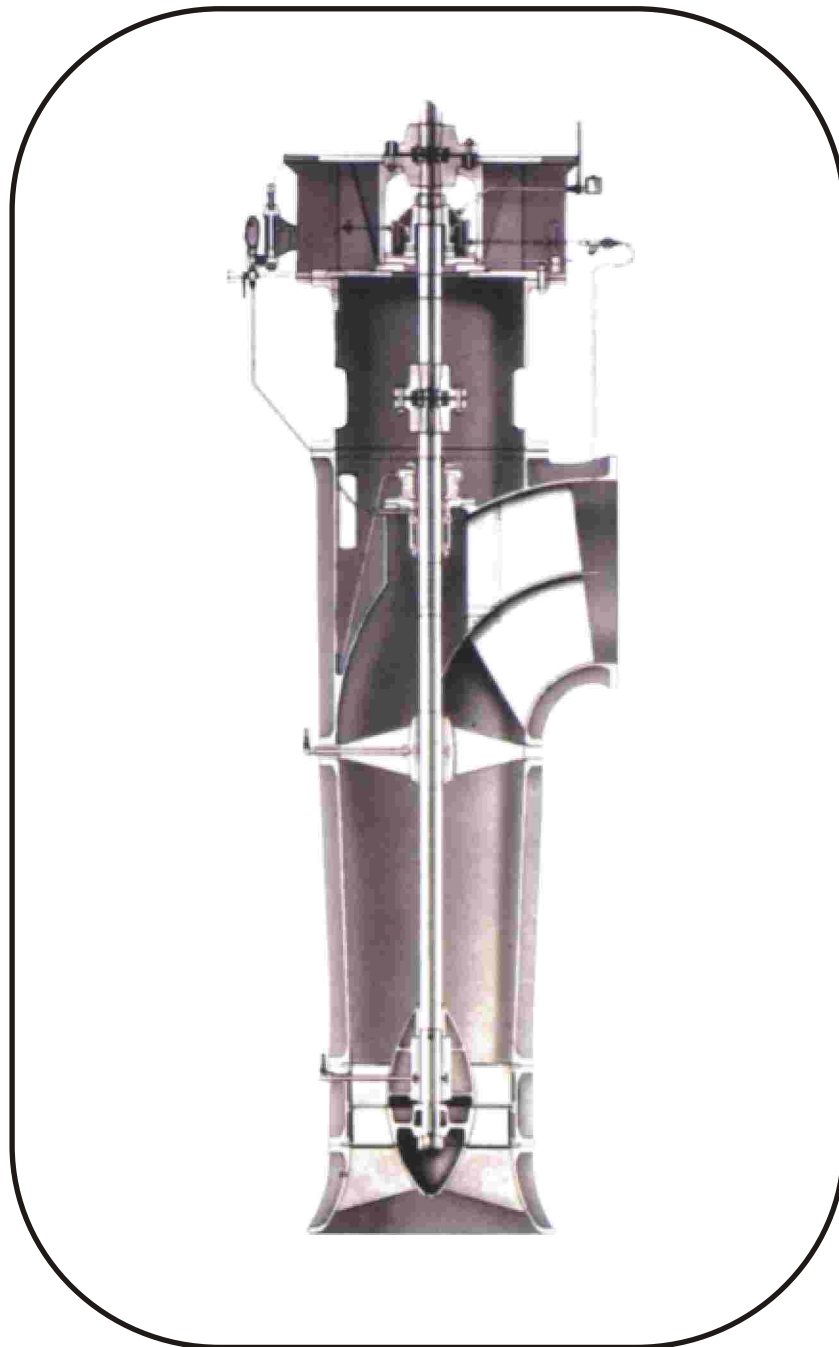

ZLB & ZLQ SERIES VERTICAL AXIAL FLOW PUMP



THONG FATT JAYA MACHINERY HARDWARE SDN. BHD.

同發機械五金有限公司 (176024-V)

707-709, Jalan Kuala Kangsar, Taman Tasek Jaya,
31400 Ipoh, Perak. Malaysia.
Tel: 00-605-5468 659, 5455 751, 5479 196, 5454 107
Fax: 00-605-5482 282, 5474 753
Email: tfjaya@streamyx.com / tfjaya@tm.net.my
Website: <http://www.thongfattjaya.com.my>

Due to the policy of constant research and development, specifications may change without prior notice.
Copyright © Thong Fatt Jaya Machinery Hardware Sdn. Bhd.

C.N.: ASP-A Section A04 / 250720062
ZLB & ZLQ - PAGE 1000

DESCRIPTION

ZLB & ZLQ Series are single stage vertical axial flow pumps. They are suitable for transferring clear water, waste water and slight corrosive water. The temperature of medium transferred is not higher than 50°C generally.

APPLICATION

ZLB & ZLQ Series are large capacity and low head pump, they are widely used in:

- * Irrigation & drainage of farmland
- * Saltworks
- * Aquaculture
- * Water supply & drainage
- * Raw sewage
- * Water circulation of power station
- * Water level control of dock
- * Metallurgy
- * Chemical industry

CHARACTERISTIC

- * High efficiency
- * Good performance of anti-cavitation
- * Simple installation and maintenance
- * Durable material: vane & guide vane adopt steel material generally. (Option: aluminium bronze or stainless steel for special requirements)
- * Smooth and clean internal surface of flow passage
- * Good inter-changability of vane and guide vane
- * Low noise

PUMP KEY (Model: outlet diameter below 40 inch)



Pump Key (Model: outlet diameter is 40 inch and above)

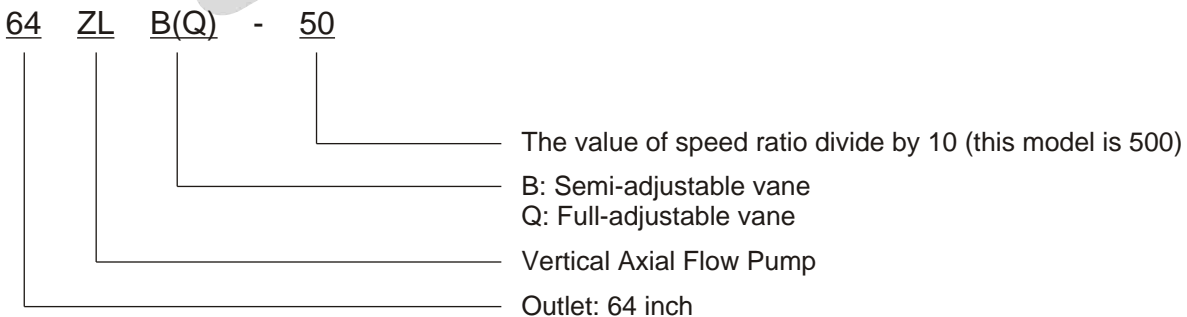

A. DOUBLE FOUNDATION VERTICAL DIVIDED STRUCTURE

1. The pump set consists of pump, transmission device, transmission shaft, etc.
2. The axial flow pump consists of inlet bell, impeller, guide vane chamber, outlet pipe, pump shaft, bearing, packing seal, etc. The both shaft ends are supported by two sets of water-lubricant rubber bearings. The surface of shaft neck is hard-chrome plating.
3. There is each set of nut on the both shaft ends and connecting with impeller casing and coupling separately. When the pump is operated, all axial force is supported by thrust bearing inside transmission device. Round nut of transmission device will adjust the axial displacement of rotor.
4. The floor foundation which support transmission device bears the axial force of pump, the weight of transmission device, motor and rotor. The weight of pump cover is supported by pump base.
5. There is a centre transmission shaft between vertical motor and pump. The motor side of transmission shaft is flexible coupling, and pump side is rigid coupling.
6. The length of transmission shaft shall be shorter than dimension L in installation dimension. There must be an additional centre bearing if the length is longer than dimension L.
7. The outlet channel of axial flow pump adopts taper diffuser generally, at the end of diffuser is discharge valve.
8. The impeller is passed the balancing inspection.
9. The space between impeller casing and guide vane chamber is 0.5%-0.6% of outlet diameter of pump.
10. The cylindroid impeller chamber and inlet bell are die-casting in one set. The vane angle is once completed according to customer's requirement, customer can not change it arbitrarily.
11. If it is a round impeller chamber, customer can stop the pump set and adjust the vane angle.
12. The space between impeller and impeller chamber is 0.1% of diameter of impeller. If the medium transferred is waste water or solid contained, this space shall be enlarged properly.
13. Rotate direction of pump: clockwise direction if look down from motor side.

B. SINGLE FOUNDATION MOTOR & PUMP MONOBLOC STRUCTURE

1. The pump and motor are connected directly by a motor base. The pump outlet can be designed on or below the foundation according to project requirement.
2. Axial water thrust convert to internal force of pump set and do not transfer to foundation, this can reduce the intensity requirement of foundation load.
3. Simple installation and maintenance, the centre transmission shaft is not required..
4. This pump can be designed as 'rotor part-draw out type' or 'whole set-draw out type'.
5. Pump shaft can be protected by a protective tube. We can draw clean water into protective tube to lubricant and cool roller bearing for medium contains solid.
6. Pump inlet channel can be ellipse inlet channel to increase performance of anti-cavitation and installation efficiency.

A1. ZLB DOUBLE FOUNDATION VERTICAL DIVIDED STRUCTURE

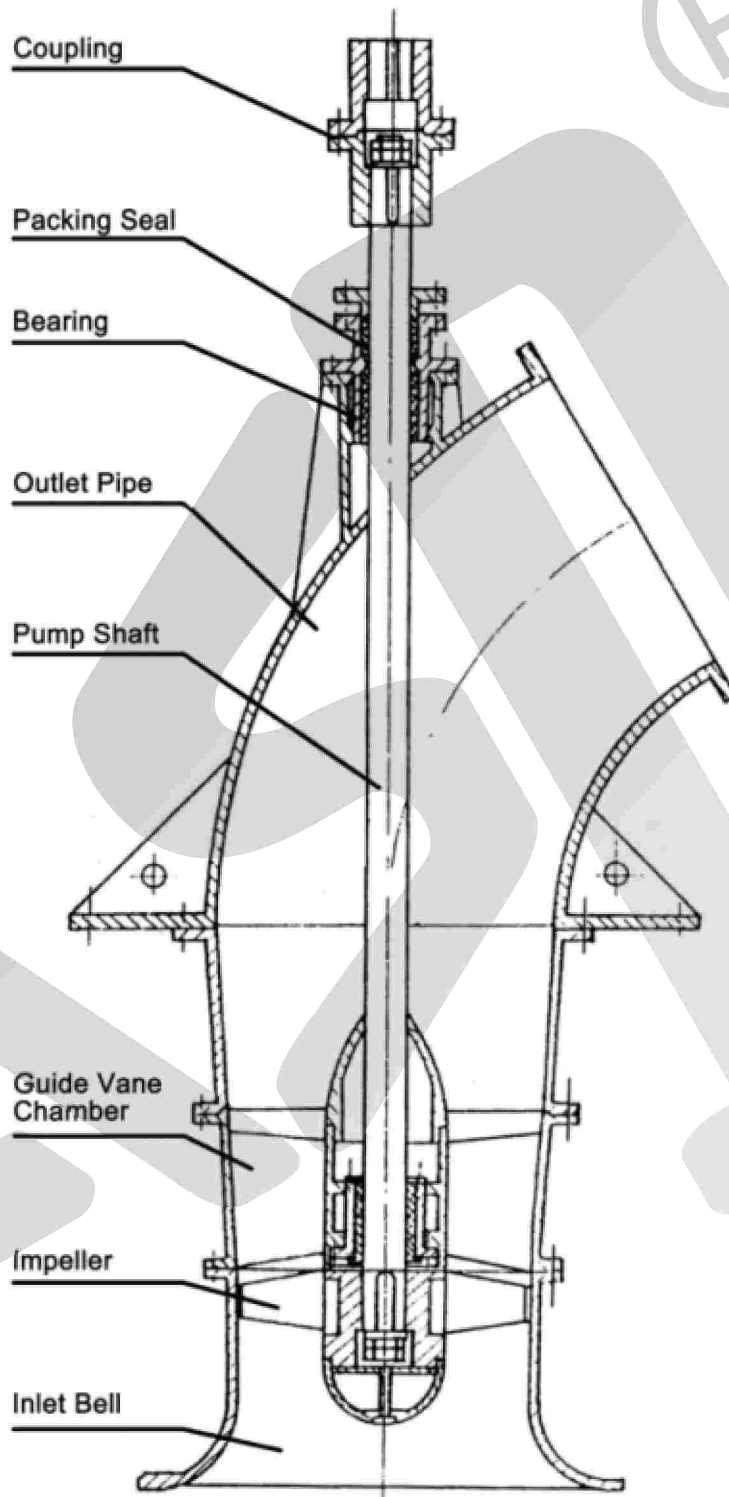

A2. ZLQ DOUBLE FOUNDATION VERTICAL DIVIDED STRUCTURE

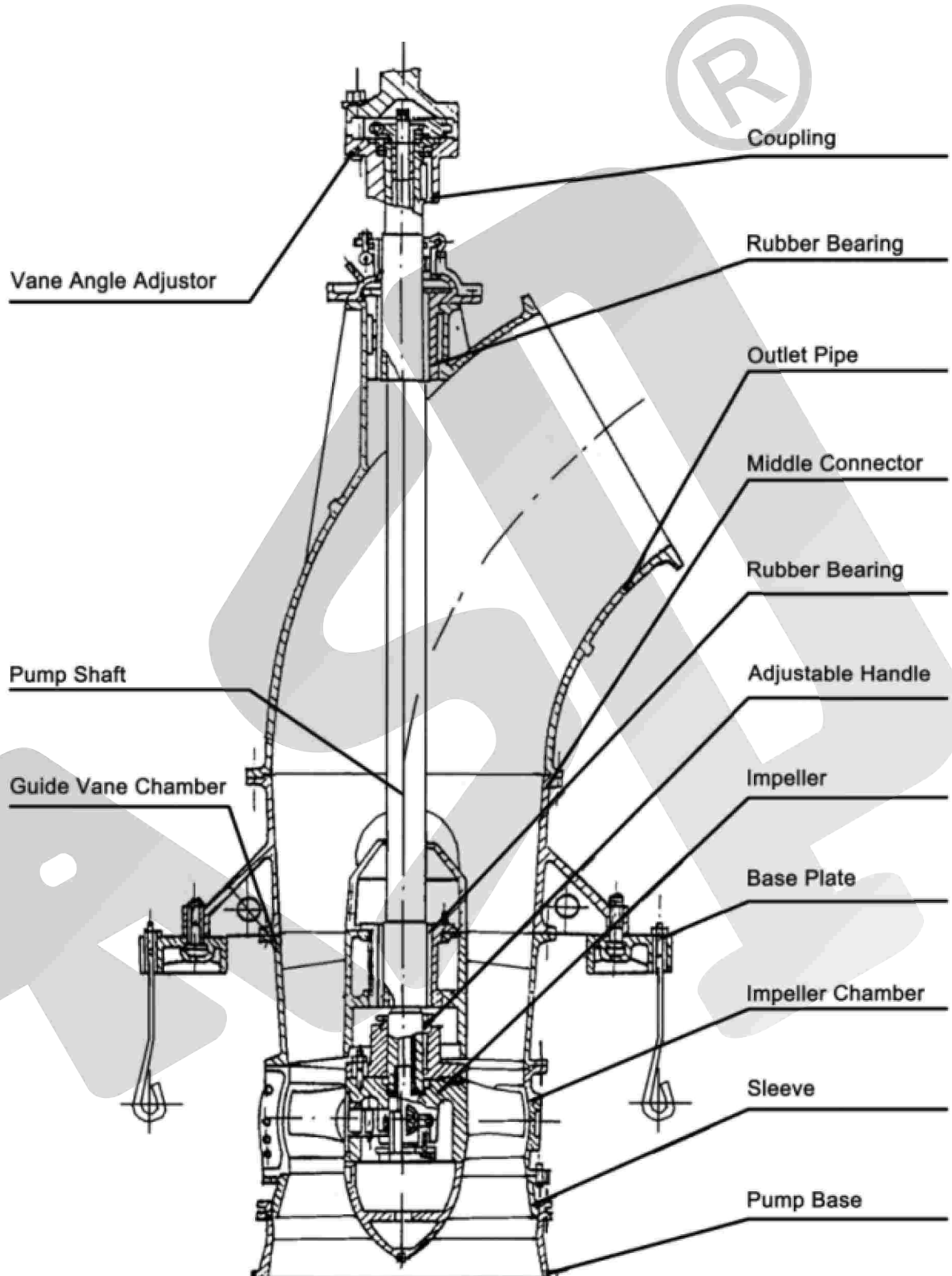

B1. ZLB SINGLE FOUNDATION MOTOR & PUMP MONOBLOC STRUCTURE

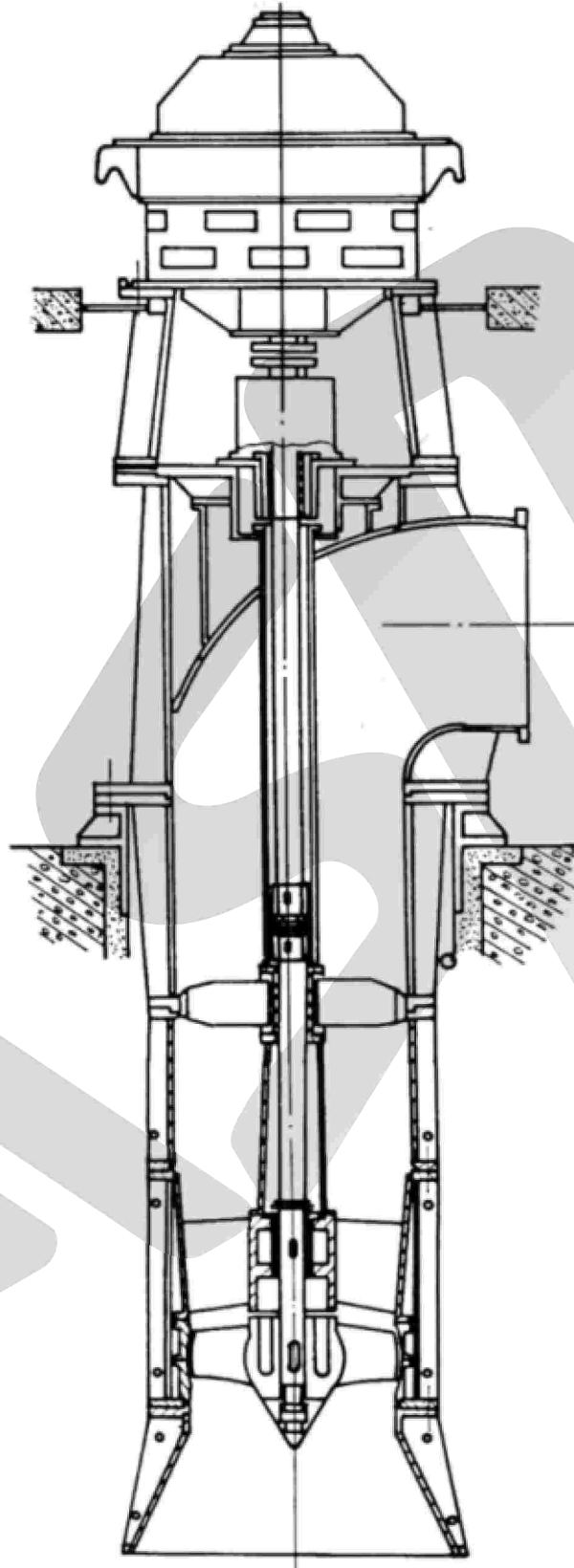

Pump outlet can be designed on the foundation

B2. ZLB SINGLE FOUNDATION MOTOR & PUMP MONOBLOC STRUCTURE

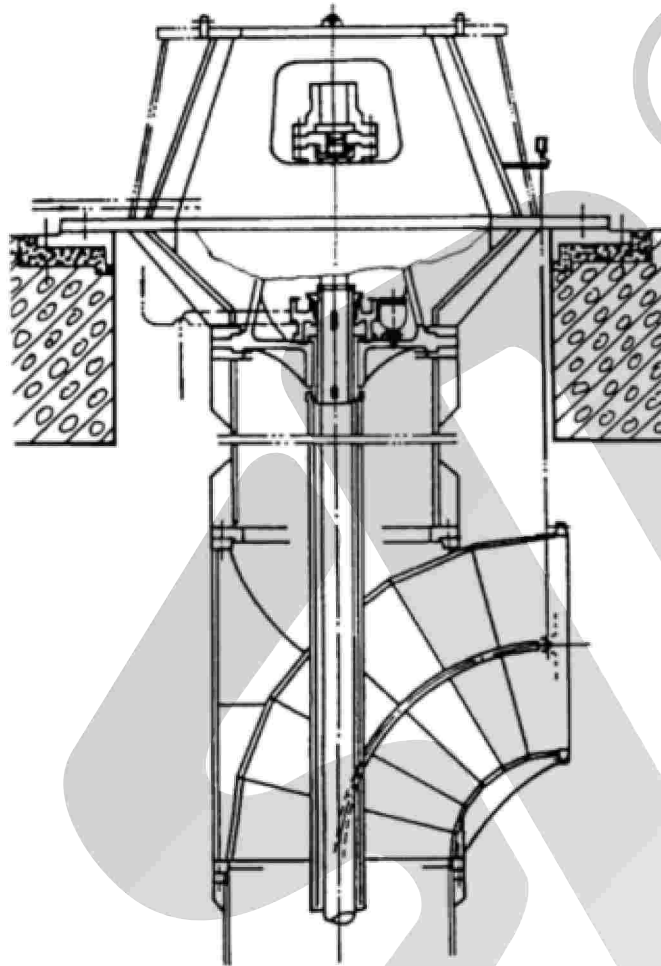

Pump outlet can be designed below the foundation

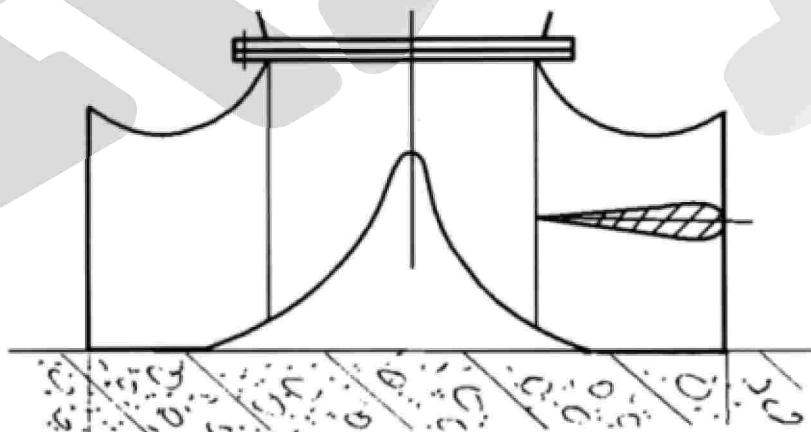

Ellipse inlet channel